



Terios SX

A NEW WAY OF THINKING

Finding a compact hatchback these days is easy. Finding one that's spacious enough inside to suit your lifestyle is another thing altogether. Unless you open your mind, think differently, and think Daihatsu Terios.

Think of the Terios as a compact hatchback by all means. It's shorter than a Golf with a better turning circle than a Clio. But don't think of it as small. Think of it as comfortable and roomy for up to 5 passengers and their luggage. Think of it as a versatile load carrier. Think of the air conditioning and reverse parking sensors that are standard on every model. Think of it as highly equipped, reliable and economical. Think of it as built in Japan with traditional Japanese quality. Think that Daihatsu is so confident of the reliability and quality of the Terios that it has a 5 year unlimited mileage warranty for your peace of mind.

Most of all, think of everything you demand your car to deliver – on city streets, country roads or motorways, for long trips, school runs, and shopping expeditions. Then read on to discover why the Terios makes life so much easier.



CONTENTS

Outside	4 – 5
Inside	6 – 7
Spacious Interior	8 – 9
Safety	10 – 11
Choose your Model	12 – 13
Advanced Engineering	14 – 15
Standard Equipment	16 – 17
Technical Specification	18 – 19



OUTSIDE

When is a 4x4 not just a 4x4? When it's the Daihatsu Terios.

The clean, simple lines of the Daihatsu Terios look equally at home on city roads and country lanes. Its ride and handling are just as suited to motorway cruising as to the occasional excursion along muddy tracks. And, although it has a powerful 1.5 litre engine that will take you anywhere you want, there is one place the Terios tries to avoid: the fuel pump.

There are three models to choose from: the Terios S, the SX and SE Automatic – all designed to make your life easier, but each with its own distinctive styling to make your choice a difficult one.

Although compact in overall length, the wheelbase on the new Terios is roughly the same as its bigger competitors. This, together with its short overhangs and small engine compartment, results in the largest possible interior space in the smallest possible body.

The design has several other key benefits too. The long wheelbase ensures that the ride is smooth and gives extra stability. Surprisingly, its overall length is shorter than that of a Golf, whilst the small turning circle is better than that of the Clio. And yet the interior space is equal to its bigger competitors.

All this put together means that the Terios is ideal for city driving – compact and, with a small turning circle, it is highly manoeuvrable. And yet if you want to be more adventurous you can be. A picnic on the beach or by the side of a river. Wherever, whatever – the Terios will take you there.



Terios SE Automatic

REAR DOORS

The rear doors open wide, in increments of 41 degrees, 60 degrees and 77 degrees, allowing passengers to get in and out safely and with ease – even when holding a child.

BRIGHTER HEADLIGHTS

Both the SX and the SE Automatic have multi-reflector quad headlights and front fog lamps, offering increased lighting range and maximum visibility in poor conditions. Whilst the Terios S has dual-headlamps with multi-reflectors incorporated to give increased brightness.

REVERSE PARKING SENSORS

Every Terios is equipped with reverse parking sensors. Combine these with its amazing manoeuvrability, excellent turning circle, compact size and good visibility, and even parking becomes a pleasure.

Minimum turning circle:
9.8m* (kerb to kerb)

*Terios SX: 10.0m (kerb to kerb)



ELECTRIC DOOR MIRRORS

All models have electric door mirrors for quick and easy adjustment. And the heated body coloured door mirrors on the SX and SE ensure rapid de-icing and de-misting for clearer rear vision.

HANDY ROOF RAILS

Additional luggage can be stored on the roof if necessary. Both the SX and SE Automatic have roof rails that allow for the easy attachment of a roof luggage carrier.



INSIDE

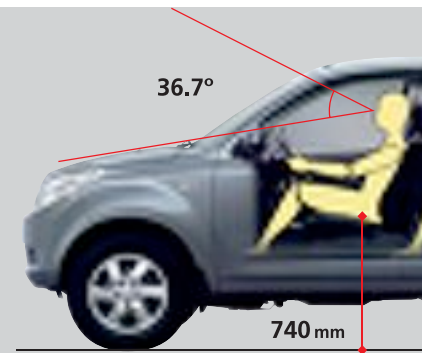

Outstanding visibility thanks to the large vertical viewing angle

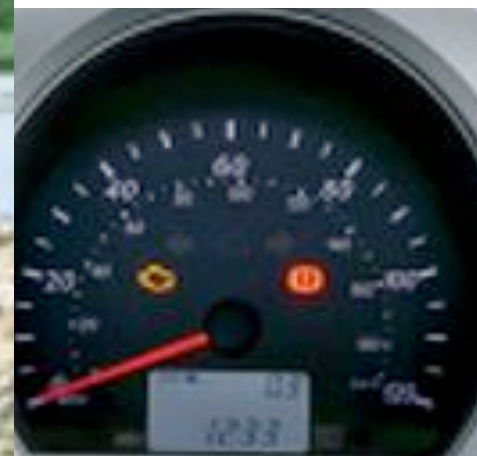

Just settle down in the driver's seat. Look at that panoramic view of the world that the high seating position gives you. Not only can you enjoy a superior view of the landscape, but with this enhanced visibility you have more time to react and take control.

Adjust the driver's seat to exactly the right angle to get a comfortable position for your arms and legs. Pump the height adjuster to get really comfortable and then raise or lower the steering column to finalise your driving position to the most comfortable possible. Now adjust the height of the front safety belt for comfort and safety and you are finished. Now you have control.

One look tells you that the interior is short of nothing. The instrument panel combines good looks with functional practicality. The integral flush-fitting RDS radio with CD player is easy to operate, thanks to large user-friendly controls.

Three large push-and-rotate control knobs for the air conditioning and ventilation, fan and temperature make controlling the climate in the cabin easy.

The instrument cluster, divided into three segments, houses the tachometer, speedometer and fuel gauge. An unusual feature is that the instrument panel has edge lighting so that it is illuminated even when the headlights are off. This means that when going through dark tunnels or heavy shadow your instruments are always easy to read. The instrument panel also has a warning light to remind you when the sidelights or headlights are turned on.

Both the SX and SE Automatic have a multi-information display whereby, with a single button, the driver can monitor time, average fuel consumption, outside temperature and the maximum driving range possible on remaining fuel.

The SX and SE Automatic not only sport heated door mirrors but, under the steering wheel, you'll find a button for the electric windscreen de-icer for those really frosty days. A leather covered steering wheel and gear knob on both models also give that extra feeling of luxury.

The Terios is equipped with a 12v power supply in the front console, while both the SX and SE Automatic also have a 12v power supply in the luggage compartment.



Terios SE Automatic



Terios SX

SPACIOUS INTERIOR

The Daihatsu Terios won't just take you to the wide open spaces. It's also full of them.

Ample distance between the driver's seat and the passenger seat means there's plenty of room for two adults to sit in comfort in the spacious cabin. The seats are also at the optimum height to ensure that the driver enjoys good visibility as well as making it easy to get in and out.

Of course, when you can comfortably carry up to 5 adults you need plenty of luggage space. So the Terios has a large luggage compartment, which the 60:40 split rear seat with fold-and-tumble mechanism can make even larger. Fold down one seat to carry long items, or fold and stow the whole rear seat to open up a flat floor luggage compartment big enough for a 26" mountain bike. The benefit of having the spare wheel mounted on the back door is that the floor height of the luggage compartment is kept as low as possible making loading and unloading so much easier. Thoughtful design has prevented the spare wheel from obscuring visibility through the rear window.

Finally, the rear seats also recline, so passenger comfort doesn't take a back seat.

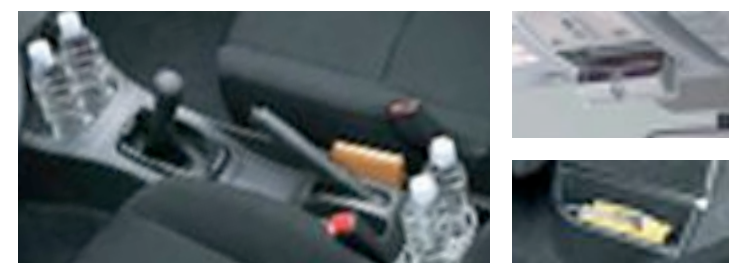
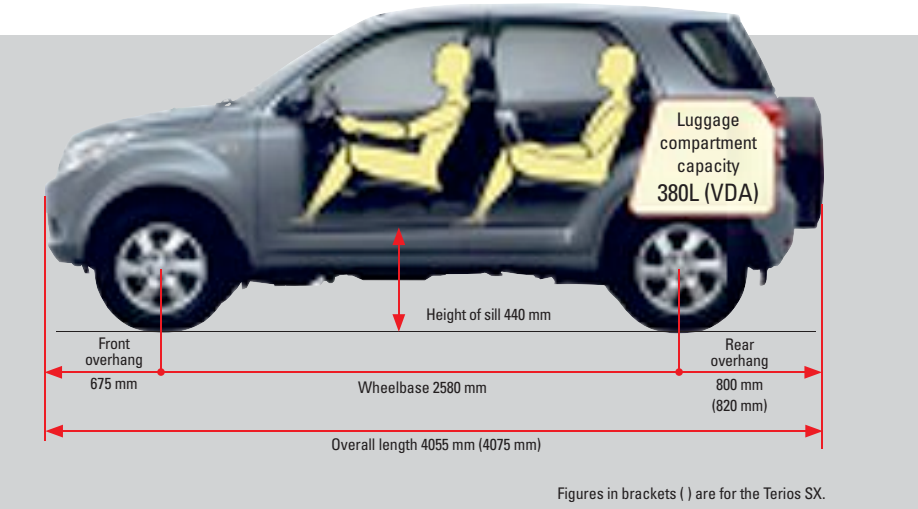

There is plenty of interior storage for all your everyday items, and to keep valuables out of sight.



Versatile load configurations mean you can carry everything from holiday luggage to mountain bikes.



Terios SX



Terios SX

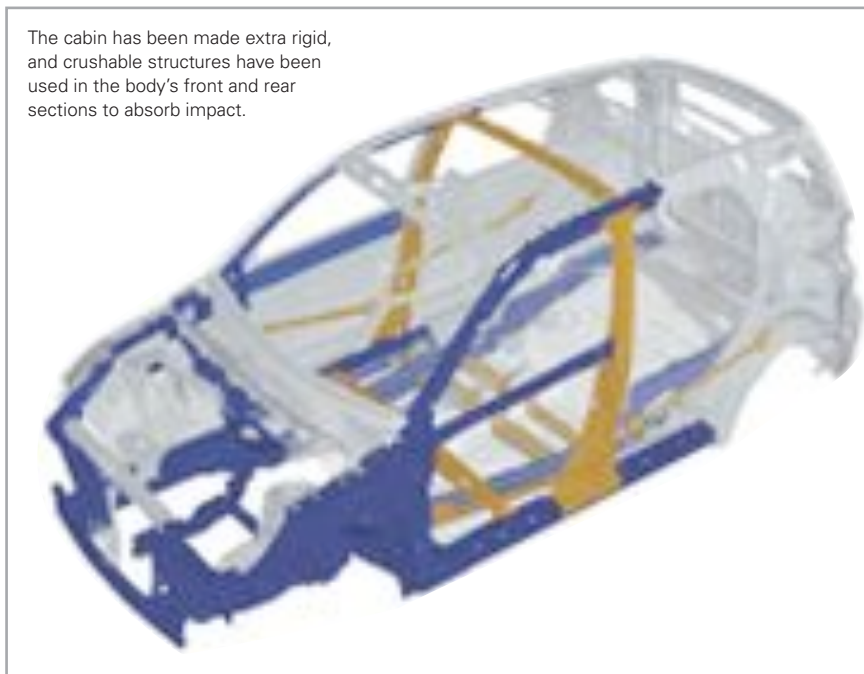

The cabin has been made extra rigid, and crushable structures have been used in the body's front and rear sections to absorb impact.

Safety is a major factor in the development of every vehicle in the Daihatsu range. The Terios takes this commitment to new heights.

With its advanced permanent 4 wheel drive system, you're guaranteed a safe and secure drive in almost any conditions. So whether it's slippery roads, steep climbs or descents, snow and ice or a torrential downpour, the Terios takes everything in its stride to give you a safe driving experience. Its 4 wheel drive system also features a lockable centre differential – so in the unlikely event that you need extra traction, you've got it.

Stopping safely and quickly can sometimes stop an accident happening. So the Terios has Anti-lock Braking (ABS), Brake Assist for more powerful braking, and Electronic Brakeforce Distribution to direct the braking power where it's needed most.

If the collision still happens, the Terios is designed to disperse the impact energy throughout its body, and an Impact Detecting Fuel Cut-Off System helps prevent further danger. Furthermore, the body structure of the Terios is also designed to minimise the impact to a pedestrian's head and legs in event of an accident.

Driver and front seat passenger are protected with front and side airbags, seatbelt pre-tensioners and force limiters. There's a cut-off switch for the front passenger seat airbag. And in the rear, there are ISOFIX anchorage points for two child seats.



At the top of the centre console is the visible warning display with safety belt not on indicators, passenger airbag off and a security indicator lamp.



Cut-off switch for the front passenger airbag.



CHOOSE YOUR MODEL



The Daihatsu Terios S gives you more than you might expect. Some competitive cars cost more and give you less. But the Terios S comes with air conditioning, electric windows, remote central locking and reverse parking sensors. What can possibly beat that? Only another Daihatsu Terios model, of course.



The Daihatsu Terios SX has the standard features of the Terios S, and more. Its looks are enhanced with alloy wheels, wider tyres two-tone wheel arch extensions and side skirts. Its practicality is increased with roof rails for extra luggage carrying capacity, and multi-reflector quad headlights and front fog lights for maximum visibility. The door handles and door mirrors are colour-keyed, whilst the electric door mirrors are also heated, and the rear windows are darkened for privacy.

*SX wheel arch extensions and side skirts are silver metallic on the grey metallic body colour, and grey metallic on all other body colours.



The Daihatsu Terios SE Automatic gives you yet another option. The same high specification as the Terios SX, but with automatic rather than manual transmission. It has its own unique alloy wheels and, whilst there are no wheel arch extensions, the colour-keyed side skirts retain the sporty look.

COLOURS



Terios SX

ADVANCED ENGINEERING

Daihatsu was established in Japan in 1907, and has been at the leading edge of engineering ever since. The Daihatsu Terios shows just what experience and technology can achieve.

Smart engine

The 1.5 litre smart engine combines powerful performance with fuel economy, and ample torque with effortless acceleration. Maximum output is 103bhp at 6,000rpm, and maximum torque is 140Nm at 4,400rpm. Yet all this performance comes from a compact power plant housed in a shorter engine compartment that keeps the car's overall length down, and its interior space and manoeuvrability up.

Powerful brakes

Start with 15" front disc brakes, then add Electronic Brakeforce Distribution, an Anti-Lock Braking System and Brake Assist, and you can stop with confidence.

Comfortable suspension

The newly developed suspension system smooths bumps, flattens ruts, increases driving stability, and reduces fatigue on long journeys.

Full-time 4WD

4WD isn't just for off-road. It's for safety in slippery conditions, quicker acceleration from standstill, and greater high speed stability. The Daihatsu Terios also features a push-button centre differential lock. This directly connects front and rear wheels, giving better traction in thick mud or deep ruts, and preventing the braking effect when front and rear wheels rotate at different speeds.

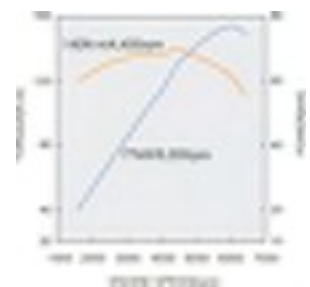
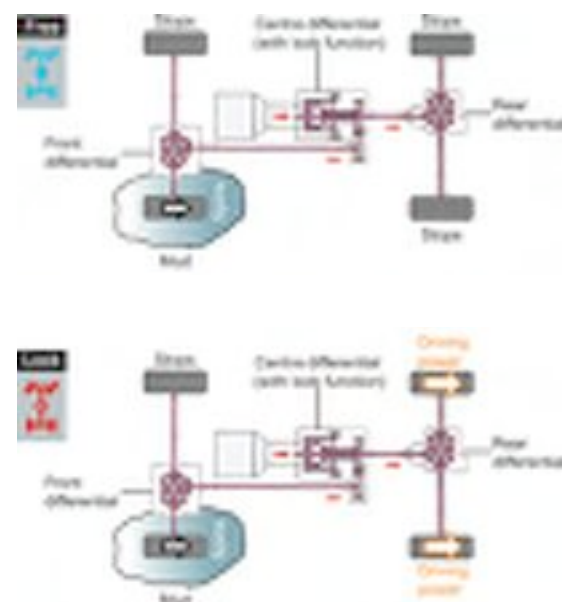

Engine: 1495cc, 4 cylinder, 16 valve, DOHC DVVT
Max Power: 103bhp (77kW) at 6000rpm
Max Torque: 140Nm at 4400rpm



Terios SX



Terios SX

STANDARD EQUIPMENT

The new Terios is loaded with an extensive range of standard equipment. Just look at everything that is included.

Few other cars come close to matching the level of equipment that the Terios offers as standard, but that doesn't mean you can't personalise your new Terios a little, there's also an accessories range full of stylish finishing touches. Just ask your Daihatsu dealer for details.

5 Year Unlimited Mileage Warranty
5 Year Roadside Assistance
6 Year Body Anti-Perforation Warranty



SAFETY & SECURITY	S	SX	SE Auto
Anti-lock braking system with EBD	●	●	●
Twin airbags and side airbags	●	●	●
Passenger airbag de-activation switch	●	●	●
3 x 3-point ELR rear seatbelts	●	●	●
Front and rear height adjustable head restraints	●	●	●
Front seatbelt pre-tensioners with load limiters	●	●	●
Childproof rear door locks	●	●	●
Engine immobiliser	●	●	●
ISOFIX child seat fixings in rear	●	●	●

STYLE & SOUND	S	SX	SE Auto
16" Alloy wheels 5 spoke	—	●	—
16" Alloy wheels 6 spoke	—	—	●
16" Alloy full-size spare	—	●	●
16" Steel wheels with wheel trims	●	—	—
16" Steel full-size spare	●	—	—
235/60 R16 tyres	—	●	—
215/65 R16 tyres	●	—	●
Body coloured bumpers	●	●	●
Two-tone wheel arch extensions and side skirts	—	●	—
Body colour side skirts	—	—	●
Black front grille with chrome surround	—	●	●
Grey front grille	●	—	—
Black electric door mirrors	●	—	—
Body coloured electric heated door mirrors	—	●	●
Body coloured door handles	—	●	●
Black window surround	—	●	●
Roof rails	—	●	●
Rear side doors and tailgate – dark tinted privacy glass	—	●	●
Silver painted inner door grip	—	●	●
Silver centre console	●	●	●
Silver instrument surround	—	●	●
Dark grey instrument surround	●	—	—
Integral flush surface RDS radio with single CD player	●	●	●
Roof mounted aerial	●	●	●
Four speakers	●	●	●

COMFORT & EQUIPMENT	S	SX	SE Auto
Driver's seat height, slide and recline adjustment	●	●	●
Reclining 60/40 split rear seats	●	●	●
Luggage hooks	—	●	●
Remote central door locking	●	●	●
Power steering	●	●	●
Centre differential lock	●	●	●
Height adjustable steering column	●	●	●
Leather steering wheel and gear knob	—	●	●
Sunvisors with covered vanity mirrors	●	●	●
Remote fuel flap release	●	●	●
Front 12V power outlet	●	●	●
Rear 12V power outlet	—	●	●
Height adjustable front seatbelts	●	●	●
Multi information display – clock, average fuel consumption, driving range, outside temperature with ice warning	—	●	●
Tachometer	●	●	●
Low fuel warning light	●	●	●
Lockable illuminated glovebox	—	●	●
Glovebox	●	●	●
Sunglasses holder in overhead console	—	●	●
Front and rear cup holders	●	●	●
Front and rear door storage pockets	●	●	●
Seat back pockets	●	●	●

CLIMATE & VISION	S	SX	SE Auto
Air conditioning	●	●	●
Front electric windows (auto down on driver's side)	●	●	●
Rear electric windows	●	●	●
Electric door mirrors	●	●	●
Electric heated door mirrors	—	●	●
Electric windscreen de-icer	—	●	●
Mudguards front and rear	●	—	—
Front fog lights	—	●	●
Multi-reflector quad lamp headlights	—	●	●
Dual lamp headlights	●	—	—
Internal headlamp levelling	●	●	●
Heated rear window	●	●	●
Rear wash wipe with intermittent delay	●	●	●
Front map lights	—	●	●
Luggage light	●	●	●
Rear fog light	●	●	●
Reverse parking sensors	●	●	●



TECHNICAL SPECIFICATION

ENGINE	
Engine Type – Petrol	4 cylinder in-line 16 valve DOHC DVVT
Capacity (cc)	1495
Max power (bhp @ rpm)	103 @ 6000
Max torque (Nm @ rpm)	140 @ 4400
Bore / Stroke (mm)	72.0 x 91.8
Fuel system	electronic fuel injection
Emission control	Euro IV

PERFORMANCE	S	SX	SE Auto
Maximum speed (mph)	99	99	93
Acceleration, seconds (0-62 mph)	12.4	12.6	14.0

TRANSMISSION	S	SX	SE Auto
5-Speed Manual	●	●	—
4-Speed Automatic	—	—	●
Permanent four wheel drive with centre differential lock	●	●	●

SEATS	
Seats	5

SUSPENSION & BRAKES	
Front suspension	Independent McPherson struts with coil springs
Front anti-roll bar	Standard
Rear suspension	5 link rigid axle with coil springs
Rear anti-roll bar	Standard
Steering system	Rack and pinion with hydraulic power assistance
Front brakes	15" disc brakes
Rear brakes	Drum

WHEELS	S	SX	SE Auto
Wheels	Steel 16x6J	Alloy 16x6.5J	Alloy 16x6J
Tyres	215/65R16	235/60 R16	215/65R16

WEIGHT	S	SX	SE Auto
Kerb weight	1170	1190	1200
Gross vehicle weight	1720	1720	1720
Maximum roof load weight	50	50	50

MAX TOWING WEIGHTS (KG)	
Trailer with brakes	1350
Trailer without brakes	400
Maximum nose weight	55

ANGLES (DEGREES)	
Angle of approach	38
Angle of departure	37
Ramp break over angle	24

FUEL CONSUMPTION (MPG)	S	SX	SE Auto
Urban	29.1	28.8	26.4
Extra urban	40.4	39.8	39.8
Combined	35.8	34.9	33.2

FUEL CONSUMPTION (LITRES/100KM)	S	SX	SE Auto
Urban	9.7	9.8	10.7
Extra urban	7.0	7.1	7.1
Combined	7.9	8.1	8.5
CO ₂ (g/km)	185	190	201
Fuel tank capacity (litres)	50	50	50

INSURANCE GROUPS	S	SX	SE Auto
Insurance groups	7	8	8

DIMENSIONS (MM)	S	SX	SE Auto
Overall length	4055	4075	4055
Overall width	1695	1745	1695
Overall height	1690	1740	1740
Front overhang	675	675	675
Rear overhang	800	820	800
Wheelbase	2580	2580	2580
Track (front)	1450	1450	1450
Track (rear)	1460	1480	1460
Ground clearance	190	190	190
Wading depth	700	700	700
Turning circle (tyre)	9.8	10.0	9.8
Turning circle (body)	10.4	10.6	10.4
Width of boot	1290	1290	1290
Boot floor length	745	745	745
Luggage area volume to windowline – seats up (litres)	380	380	380
Luggage area volume to windowline – seats folded (litres)	778	778	778
Luggage compartment floor height	640	640	640

