

# Materia

unique and versatile

designed to suit your lifestyle

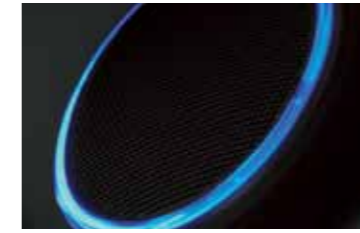

**If you're looking for a car that's as individual as you are, you've found it. With its combination of stunning lines, sporty features and overwhelming practicality, the Daihatsu Materia could just about be every car you've ever wanted, in one.**

**The first thing you'll notice is its highly distinctive and unrivalled appearance. At the wheel of the Materia, you'll enjoy all the confidence that comes with driving an MPV that really stands out from the crowd.**

Spacious and capacious. The interior of the Materia is a feat of engineering in itself. The sliding rear passenger seat means you can maximise on comfort for rear seat passengers or increase the size of the boot, quickly and efficiently, as each trip demands. It also splits so to allow for numerous seating configurations. Whatever your hobby, whatever the task, you'll be amazed at how the Materia swallows up luggage, golf bags, picnic baskets and even surf boards with ease.

Available as a 1.5 litre manual or automatic, the Materia's engine is powerful and responsive, yet still very economical. Many features come as standard. These include air conditioning, front fog lamps, alloy wheels and reverse parking sensors. The audio system is rather special too. Whether you're into Mozart or Madonna, an RDS tuner with two tweeters in the dashboard, switchable blue illumination on the two front door speakers and another two speakers in the rear doors will give you mile after mile of audio pleasure.

With an MPV that has such distinctive styling, great performance, practicality and terrific value, what more could you ask for? Our guarantee, of course. Every new Daihatsu Materia comes with our 3 year unlimited mileage warranty, 3 years roadside assistance and 8 year anti-perforation warranty. And that means added peace of mind for you.



# Outside

distinctive and stylish

stand out from the crowd



There's more to the Materia's unique exterior styling than first meets the eye. Each well-considered feature has been designed, not only to look the business, but to make driving easier and more enjoyable too.

Tinted windows not only look cool, but also help to keep the interior cool in summer and to give you more privacy. The clean lines of the tailgate are complemented by the silver garnish, which blends seamlessly into the rear light cluster and incorporates chrome strips and an acrylic lens finish. And attractive 15" alloy wheels add an undeniably sporty touch.

The front grille incorporates dual horizontal chrome strips with integrated indicator lamps to combine style and functionality.



**Offset bee sting aerial**

**Tinted privacy glass**  
Helps keep you cool in the summer and provides rear occupants with a more private and ambient environment.

**Black window surround**

**Colour keyed door handles**

**Front fog lamps**  
Not only enhance your visibility in difficult conditions, but also act as an attractive styling feature for the Materia's front bumper.

**Tailgate garnish**

The decorative garnish's chrome strips and acrylic lens finish combine with the rear lights to give the back of the car a clean and stylish look.

**Alloy wheels**

The alloy wheels not only look good, but, because they are lighter and stronger than steel wheels, the ride and handling is improved.

**Body coloured side skirts**

Help protect the body from being chipped by stones thrown up from the road whilst driving, and also create a sportier look to the body styling.

**Colour keyed electric door mirrors**

Electric door mirrors are convenient and easy to operate and stylish front fog lamps ensure optimum visibility in all driving conditions. Even the roof mounted aerial has been offset so that it's easier to unscrew for the car wash.

# Inside

space and storage

flexible space to suit your needs



**There's no doubt that the Materia offers an impressive amount of personal space for its size. But what really sets it apart is its flexibility. Whether your rear seat passengers need more leg room on a long trip, or you need a bigger boot for bags and gear, the Materia's multi-purpose interior will cope with your every need.**

Comfortable seats and an attractive, refined interior make for a relaxing and enjoyable ride. Getting in and out is made easier by wide opening doors and seats set at an optimal height from the ground.



Reclining seats give room to stretch out and relax



Large, 619-litre (VDA) luggage capacity with wide-opening tailgate for easy loading



Room for items up to 2200mm long



Seating for three, with loads of luggage space



The tailgate opens to a height of almost 2 metres for easy loading and unloading. It'll also keep you dry in the rain.

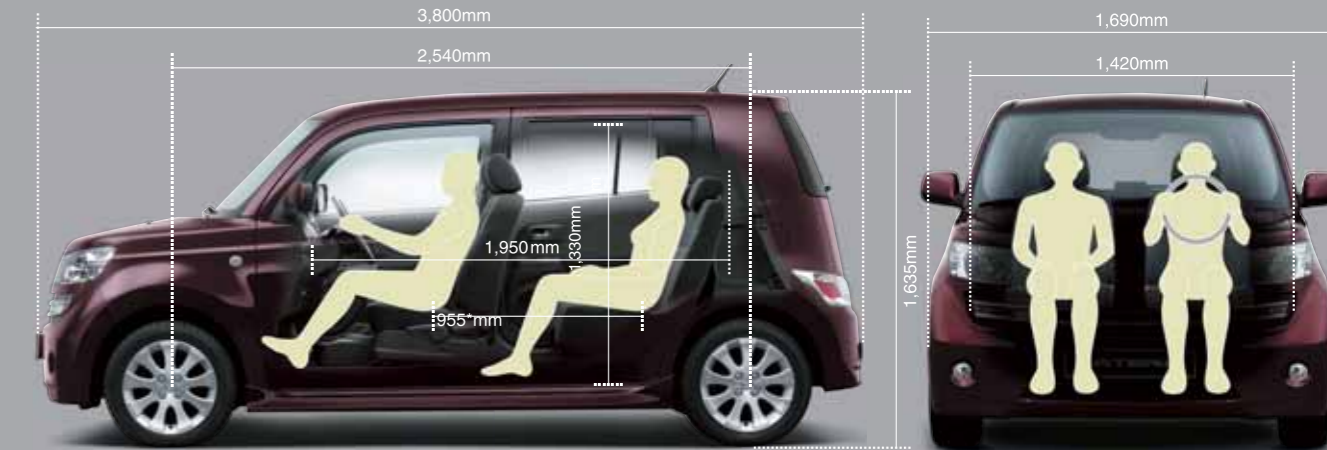

### High-efficiency Package

Wheel placement at the extreme front and back plus a wide track is one of the secrets to giving such a compact car so much interior space.



60:40 split reclining rear seat with 160mm slide adjustment for legroom and luggage capacity control.



Tilt steering, driver's seat height adjuster and height adjustable seat belt anchors ensure that your driving position is as comfortable as possible.

# Inside

equipment and features

equipped for anything



However many admiring glances the Materia gets for its unique and handsome exterior, it's the interior that you, as the driver, will mostly be faced with. No detail has been overlooked. The layout of the cabin is every bit as distinctive as the exterior and not surprisingly, the emphasis is very much on comfort with style.

The richly contoured, high-quality instrument panel features optimally positioned controls and plenty of storage spaces. The large heating controls mean you can operate the air conditioner without taking your eyes off the road.

The centre mounted meter display with a tachometer not only ensures all vital information is highly visible and easy to read, but also adds to the uncluttered appearance of the cabin. And with air conditioning as standard you will always be comfortable come rain or shine.

Flush-surface CD Tuner with black finish that can even play WMA and MP3 CDs.

Blue illumination on front door speakers that can be switched on or off



Anti-theft immobiliser system



6 speaker layout comprises two front door speakers, two rear door speakers and two dashboard mounted tweeters combined with a built in amplifier that produces a total output of 160 watts.



Centre coin box



Passenger glove box



Driver's side utility box



Front door-trim pockets



Driver's side under-tray



Seatback pocket



Under-floor deck box in the boot for storage of tools and other items.



Door-trim bottle holders.

# Technology

performance, economy & safety

advanced engineering to meet your needs

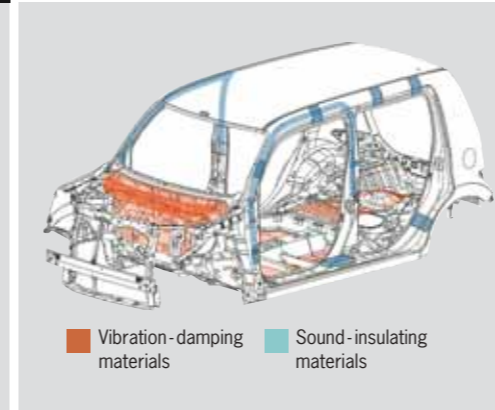
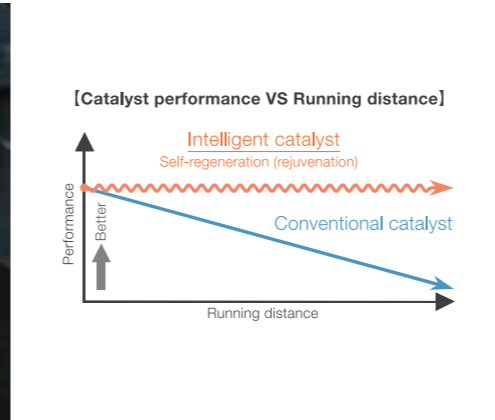
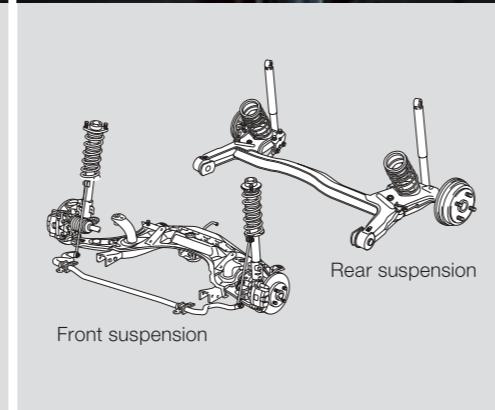
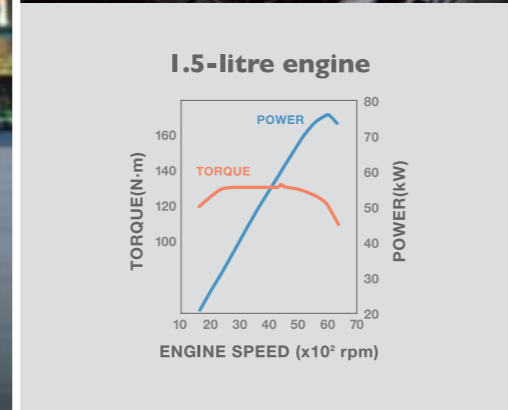

## Intelligent Catalyst

Whereas the performance of ordinary palladium catalysts declines with use, this revolutionary and pioneering intelligent catalyst is self-regenerating to ensure long life.

Large 14" ventilated front brake discs provide superior response and stopping power.

## Active Safety

ABS (Anti-lock Braking System) with EBD (Electronic Brake-force Distribution), which prevents the brakes from locking during sudden braking.

Dual SRS Airbags for driver and passenger, and SRS side airbags help reduce impact force in the event of a collision. A cut-off switch (pictured) for the passenger seat airbag is also featured to reduce risk of injury to young children when travelling in the front passenger seat.

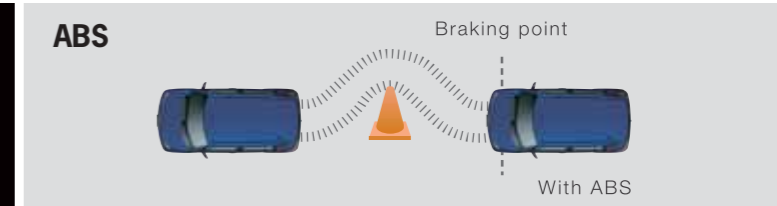

The high-rigidity body was tested in line with European and other global standards to verify survivor space in the event of a collision.

Impact absorbing hood, bumper and front end design help reduce pedestrian injury in the event of collision.

Seat belt pre-tensioners and force limiters provide restraint while helping to reduce forces applied to the torso.

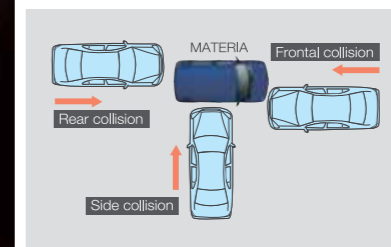
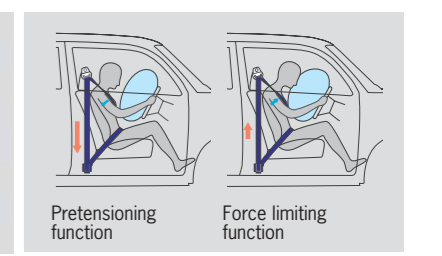

Tests simulating collisions with heavier passenger cars have been conducted from the front, side and rear. An impact-detecting fuel cut-off system helps prevent secondary injury.

More than good looks and practicality, the engineering beneath the Materia's shiny exterior is just as impressive. Skilful engineering makes sure you get the best driving performance, safety for all your passengers and fuel efficiency that will limit environmental impact.

## 1.5 litre DVVT engine

The modified 1.5 litre DVVT engine combines powerful output for safer driving with outstanding low and mid-range torque, as well as excellent fuel efficiency and reduced emissions.

## Suspension

Designed specifically for Materia, the rigorously tested suspension ensures a comfortable ride and precise steering.

Vibration-damping and sound-insulating materials reduce engine and road noise to ensure a tranquil driving experience.

Large multi-reflector high and low-beam headlamps give brighter night-time illumination.

# Equipment

choice and practicality

the usual extras come as standard

## Body colours



White

Grey Metallic\*



Dark Red Mica Metallic\*



Silver Metallic\*



Dark Blue Mica Metallic\*



Black Mica Metallic\*

The Materia is available in any one of the exciting colours shown below, each one specifically chosen to beautifully accentuate the Materia's stunning exterior, and to give you plenty to choose from when it comes to making that very personal, final style decision.



## Style and Sound

- Alloy wheels
- 185/55R15 tyres
- Dark tinted privacy glass for rear occupants
- Body coloured bumpers
- Body colour side skirts
- Black window surround
- Body colour electric door mirrors
- Body coloured door handles
- Chrome plated inside door handle
- Decorative tailgate garnish
- Body coloured tailgate handle
- Integral Flush Surface RDS Radio with single CD Player
- Offset rear roof aerial
- Two dashboard mounted tweeters
- Two front door speakers with switchable blue illumination
- Two rear door speakers

## Climate and Vision

- Air conditioning
- Front electric windows (auto down on driver's side)
- Rear electric windows
- Electric door mirrors
- Front fog lamps
- Heated rear window
- Rear wash wipe with intermittent delay
- Front map lamps
- Luggage lamp
- Reverse parking sensors
- Rear fog light

## Comfort and Equipment

- Cloth upholstery
- Driver's seat height adjustment
- Split 60/40 sliding & reclining rear seats
- Remote central door locking
- Speed sensing power steering
- Height adjustable steering column
- Sunvisors with covered vanity mirrors
- Remote fuel flap release
- Front 12V power outlet
- Height adjustable inertia front seatbelts
- Digital clock
- Tachometer
- Lights on warning buzzer
- Glovebox
- Front & rear cup holders
- Front passenger seat back pocket
- Front door storage pockets

## Safety and Security

- Anti-lock braking system with Electronic Brakeforce Distribution (EBD)
- Driver, passenger and side airbags
- 3 x 3-point inertia rear seatbelts
- Front and rear height adjustable head restraints
- Front seatbelt pre-tensioners with load limiters
- Child proof rear door locks
- Engine immobiliser
- ISOFIX child seat fixings in rear x 2
- Front seatbelts not fixed warning lamps and buzzer
- Rear retractable luggage cover

At Daihatsu, we pride ourselves in offering outstanding value for money on all our models, and the Materia is no different. Everything listed comes as standard on both the manual and automatic models, and they have all been included to enhance your enjoyment, comfort and convenience. We wouldn't have it any other way.



\*Metallic paint is an optional extra at extra cost.

# Specifications

facts and figures

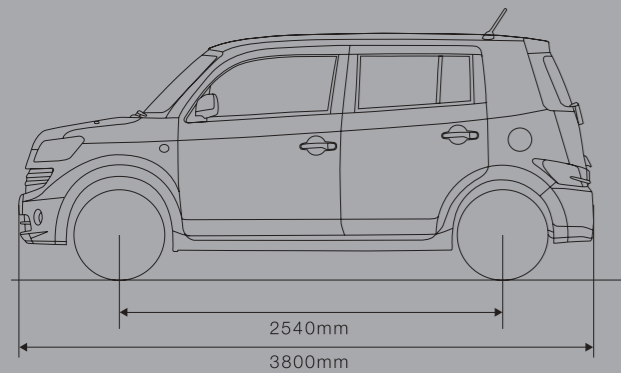
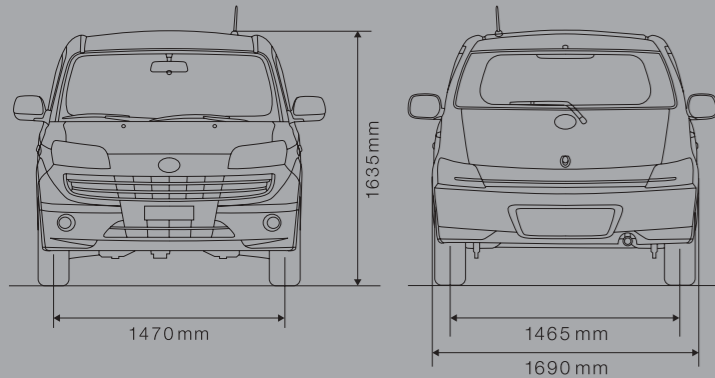

everything you need to know

Engine Data	Manual	Automatic
Engine Type	DOHC, DVVT	DOHC, DVVT
Cylinders	4	4
Valves per cylinder	4	4
Capacity (cc)	1495	1495
Maximum output (bhp)	102 @ 6000 rpm	102 @ 6000 rpm
Maximum torque (Nm)	132 @ 4400 rpm	138 @ 4400 rpm
Bore & stroke (mm)	72 x 91.8	72 x 91.8

Transmission	Manual	Automatic
Number of forward gears	5	4
Gearbox type	Manual	Automatic
Driven wheels	Front wheel drive	Front wheel drive

Wheels and Tyres	Manual	Automatic
Wheel type	Aluminium	Aluminium
Tyre size	185/55R15	185/55R15

Capacities	Manual	Automatic
Fuel tank (litres)	40	40

Fuel Consumption (mpg)	Manual	Automatic
Urban (mpg)	31.7	29.7
Extra Urban (mpg)	46.3	45.6
Combined (mpg)	39.2	37.7

Fuel Consumption (litres)	Manual	Automatic
Urban (litres)	8.9	9.5
Extra Urban (litres)	6.1	6.2
Combined (litres)	7.2	7.5

Performance	Manual	Automatic
Maximum speed (mph)	106	102
Acceleration 0 - 62 mph (secs)	10.8	13.7

Emissions	Manual	Automatic
CO <sub>2</sub> (g/km)	169	176

Sound Levels	Manual	Automatic
Moving dB(A)	72.5	70.2

Turning Circle	Manual	Automatic
Kerb to kerb (metres)	9.8	9.8

Seating	Manual	Automatic
Number of seats	5	5

Dimensions	Manual	Automatic
Overall length (mm)	3800	3800
Overall width (mm)	1690	1690
Overall height (mm)	1635	1635
Wheelbase (mm)	2540	2540
Track front (mm)	1470	1470
Track rear (mm)	1465	1465
Ground clearance (mm)	150	150

Luggage Capacity (to window line)	Manual	Automatic
Rear seats upright (litres)	230	230
Rear seats folded (litres)	619	619

Weights	Manual	Automatic
Unladen weight (kgs)	1035	1050
Gross vehicle weight (kgs)	1600	1600
Payload (kgs)	565	550

Trailer load limits	Manual	Automatic
Braked (kgs)	1000	1000
Unbraked (kgs)	550	550

