

## The cool, irresistible Copen

Viewed from the outside, words like sporty, elegant and stylish instantly spring to mind. Get behind the wheel however, and altogether different emotions take hold. With a new high-performance 1.3 litre engine and an electrically powered retractable hardtop, you'll experience sensations of exhilaration and pure fun every time you take to the road.

Even when the weather takes a turn for the worse, the Copen's retractable hardtop can react in just 20 seconds. Just park up, flip 2 clips, hit a switch, and you're safely protected from the elements.





### Impressive performance. Sure-footed handling

If you love the open road and the open air, you'll love the Copen. With its advanced engine technology, you'll find it quick off the mark – yet delightfully slow to get through a tank of fuel.

## Slick in the city. Cool on the coast

Welcome to a new kind of style statement. In the city. By the beach. Or simply parked on your drive. Wherever you travel, the stunning design demands that other drivers sneak a second look. Spirited, fast and drop-dead gorgeous, the Copen is packed with surprises. And now with optional Recaro seats\*, you can feel just as sporty on the inside as the Copen appears on the outside.



## Respond, adapt, move on

## In just twenty seconds, you can change your open top sports car for the comfort of a coupe

What's more, compared to a conventional soft top, the Copen's aluminium roof gives you better protection against both weather and noise, not to mention unwanted intruders. In fact, with the electrically operated roof in place, you benefit from sound insulation that compares with any coupe. A heated rear window further sets it apart from soft top alternatives. While, with the roof down, its rear wind deflector screen helps maintain your cool by minimising wind swirl round the cabin.



The boot has a luggage capacity of 210 litres (VDA) when the roof is up. It also features an easy closing mechanism – simply press the lid down until it touches the latch, and the lock will automatically engage and close the lid securely for you.



Roof locks    Roof operating switch    Roof operating indicator



Wind - and Sunvisors



Boot space with the roof up

## Power that responds to your every touch



## A well balanced K3-VE engine

With its powerful engine and lightweight body, Copen boasts a power-to-weight ratio that assures you of an exhilarating sport-driving experience. What's more, the proven K3-VE engine efficiently offers maximum output of 86bhp, and meets EURO IV emission standards.

Max. output : 86bhp / 6,000rpm

Max. torque : 120N·m / 4,400rpm

## The self-regenerating "Intelligent Catalyst" – a Daihatsu exclusive

The K3-VE engine's exhaust purification system employs a revolutionary "Intelligent Catalyst" to ensure clean exhaust emissions over a longer period of time. Developed by Daihatsu, it uses a self-regenerating function to maintain its stable catalytic performance.

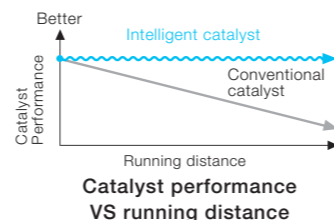

## Light yet rigid, even the body is designed for sport-driving pleasure

With a minimised weight, key underbody joints are braced and rigorously reinforced to assure higher rigidity than comparable fixed-roof models, and the upper body uses aluminium components for the bonnet, roof, and boot lid. The result is a superb balance of light weight and high rigidity that makes sport driving come alive.

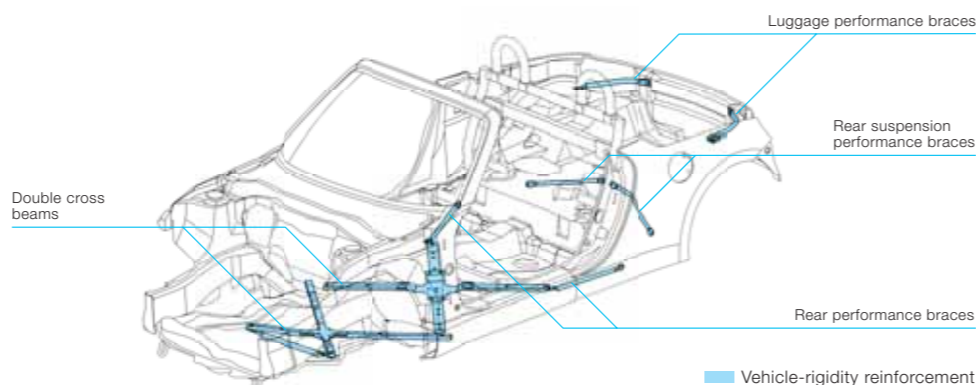

## A sporty 5-speed manual transmission for great acceleration

The gearbox is a joy to use. Its short gear lever is ideally positioned to provide a smoother and quicker gear change, aided by the special molybdenum-coated synchronizer rings within the gearbox.



## A suspension tuned for a comfortable ride and quick, responsive steering

Copen's advanced suspension system is performance-tuned by Magna Powertrain of Austria for maximum driving pleasure. Together with the car's low centre of gravity and large-diameter front and rear stabilisers, it assures excellent tracking and cornering stability. Gas shock absorbers are mounted front and rear, further contributing to superb straightline driveability and quick steering response. Add Copen's short wheelbase and light, rigid body to the mix and you've got a light, road-hugging machine that lets you steer with confidence.

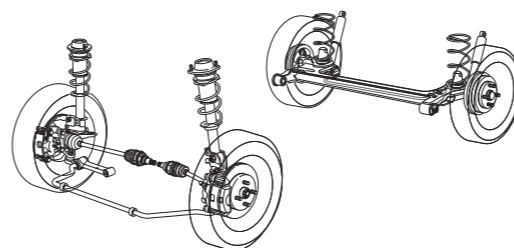

## High level safety for fun, confident driving

## Outstanding collision safety by design

A high-rigidity cabin helps protect vehicle occupants, and front and rear crushable zones effectively absorb and distribute impact force in the event of a collision. Large cross members, side impact beams, and three impact-absorbing pads in the door and trim provide additional protection against side collisions. Numerous offset collision and rollover tests simulating actual accident conditions were also conducted to assure a high level of safety – so you can enjoy the peace of mind that lets you experience the pleasure of open-air cruising to the fullest.



## SRS air bags – added assurance in case of collision

SRS (Supplementary Restraint System)\* air bags help protect the driver and passenger. The air bags supplement the seat belts by inflating instantly to cushion the head and torso when a major frontal impact occurs. Both seats are also equipped with 3-point ELR belts with pretensioners and force limiters.

\*Front SRS air bags will not inflate on minor frontal impact, on side or rear impact, or when the car overturns. They are designed to provide supplementary protection in combination with the seat belts, which should be worn at all times.

## ABS with EBD control

The Copen features 14-inch ventilated front disc brakes and an ABS (Anti-lock Braking System) that incorporates EBD (Electronic Brake-force Distribution) control. With EBD, the brake force is optimally distributed among all four wheels to ensure safe, effective braking. During sudden braking, supplementary assist power helps generate powerful stopping force even if the brake pedal is not fully depressed.



14-inch ventilated front disc brakes



Starting point of braking

## Impact-sensing release system

An impact-sensing power door lock release system helps prevent secondary damage and injury following an accident. When the system senses impact, it automatically shuts off the fuel supply to help reduce the danger of fire, unlocks the doors to allow safe and easy exit, turns on the room lamps, and activates the hazard flasher to alert other motorists.

## High-visibility lamps

Powerful headlamps feature projector-type low beams for excellent visibility. A high-mounted LED brakelamp also makes you more visible to drivers approaching from the rear.



High-mounted brakelamp (LED)



Coloured electric door mirrors    Dual exhaust pipes



Lockable glove box    Cup holder



Door pockets (both sides)    Seat back pocket (passenger side)



Back panel pocket    Lockable centre console box

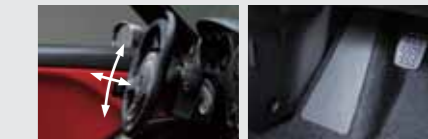

Telescopic and tilt steering    Footrest



Seat heater (only with leather pack)



Roll-bars and aero deflector

### Body Colours:



Shining Red



Silver Metallic



Steel Grey Metallic

### Interior Options:



Fabric seat (black)



Standard Steering Wheel



Genuine leather seat (red)



MOMO red leather steering wheel\*



Recaro fabric seat



MOMO black leather steering wheel\*

\*Red leather steering wheel is standard with Leather pack and black leather steering wheel is standard with Recaro seats.

# SPECIFICATION

### Engine

Number of valves	16
Cubic capacity, cc	1298
Bore & Stroke, mm	72 x 79.7
Maximum output, bhp/ps	86/87 @6000rpm
Maximum torque, lb.ft/Nm	89/120 @4400rpm
Compression ratio	10.1
Injection system	Electronic multi-point
Exhaust emission control	Regulated catalyst
Fuel grade, minimum	Premium 95 Ron unleaded
Emission control system	Complies with Euro 4

### Transmission

Gearbox	5 Speed manual
---------	----------------

### Running Gear

Front axle	Macpherson struts with coil springs
Rear axle	Trailing arm with torsion beam
Steering	Power assisted rack and pinion
Brake system	Servo assisted Ventilated front discs Rear self adjusting drums
Turning circle	9.2 metres (kerb to kerb)

### Performance

Acceleration 0 - 62mph, secs	9.5
Maximum speed, mph	112

### Fuel consumption

	L/100km	mpg
Urban	7.7	36.7
Extra Urban	5.0	56.5
Combined	6.0	47.1

Fuel tank capacity, litres	40
----------------------------	----

### Environmental Information

Carbon Dioxide emissions, g/km	140
Noise level, dB (A) Moving	71.1

### Wheels & Tyres

Wheel size	4.5J X 15
Wheel type	Aluminium
Tyre size	165/50R15
Spare wheel	None, sealing foam and tyre inflation kit

### Weights

Unladen weight, kgs	850
Gross vehicle weight, kgs	1040
Payload	190

### Maximum Luggage Capacity

With roof erected, litres	210
With roof packed in boot, litres	14

### Exterior Dimensions

Overall length, mm	3440
Overall width, mm	1475
Overall height, mm	1245
Wheelbase, mm	2225
Minimum road clearance, mm	105
Track with front, mm	1300
Track with rear, mm	1290

Seating capacity	2
------------------	---

## Standard Equipment

### Style & Sound

- Rear spoiler
- Dual exhaust pipes
- Colour keyed electric door mirrors
- Body coloured door handles
- RDS Radio with single CD Player

### Climate & Vision

- Air conditioning
- Electric windows
- Rear wind deflector
- Heated rear window
- Internal headlamp levelling
- Front fog lamps

### Comfort & Equipment

- Electrically operated hard top
- Sports seats with intergrated headrest
- Cloth upholstery
- Remote central door locking
- Height adjustable steering column
- Remote fuel flap release
- Digital Clock
- Tachometer
- Lockable centre console box
- Lockable glovebox
- Front door pockets
- Back panel pocket
- Cup holder

### Safety and Security

- Anti-lock braking system with EBD
- Driver and passenger airbags
- Roll bars - driver and passenger
- Front seatbelt pre-tensioners with load limiters
- Engine immobiliser

